

# **A NEW CALORIMETER FOR MEASURING RAPIDLY THERMAL CONDUCTIVITIES OF THE ORGANIC LIQUIDS AND THE ELECTRICALLY CONDUCTING LIQUIDS**

*Congyu Wang and Menglin Yang*

Thermochemistry Institute, Northwestern University, Xi'an 710069, P. R. China

## **Abstract**

A new calorimeter for measuring thermal conductivity of liquids has been constructed. It is wholly automatic under the computer control. The time of measurement is 1 s and the temperature rise due to heating is within 1°C. Six organic liquids and six aqueous solutions of electrolytes were employed as reference standards. The instrument was calibrated at 25°C. Its accuracy is better than 1% with a precision of about 0.2%.

**Keywords:** calorimeter, electrically conducting liquids, thermal conductivity

## **Introduction**

The measurement of thermal conductivity of liquids is very important to both practical applications and theoretical research. However, it is quite difficult to measure accurately the thermal conductivity of liquids, because of the presence of convection and radiation accompanying the measurement process.

Thermal conductivity ( $\lambda$ ) of any substance is defined by Eq. (1).

$$dQ/dt = -\lambda A(dT/dx) \quad (1)$$

where  $dQ$  is the heat transmitted in time  $dt$  along a temperature gradient,  $dT/dx$  perpendicular to an area  $A$ . It is now known that, the convection and radiation caused by the temperature gradient and measurement time tend to make experimental values too high.

Mallan [1] have collected the experimental thermal conductivities of toluene at 20°C over the past 44 years. The experimental values have decreased, year by year, from 1923 to 1967. The decrease is due to improvements in the measuring method and experimental techniques. Reid [2] pointed out that many investigators have contributed notably to the measurement of  $\lambda$  of liquids, but the results of these investigations often do not agree well, with the deviations as large as 5

to 10 percent. By reviewing, we conclude that the lower values are generally more acceptable.

The measuring of thermal conductivity of aqueous solutions of electrolytes is more difficult. The conventional 'hot wire' method is not applicable.

In order to overcome the effects of convection and radiation, the authors have constructed an experimental apparatus. The measuring time is 1 s, and the temperature rise due to heating is within 1°C.

## Apparatus

The experimental apparatus is shown schematically in Fig. 1.

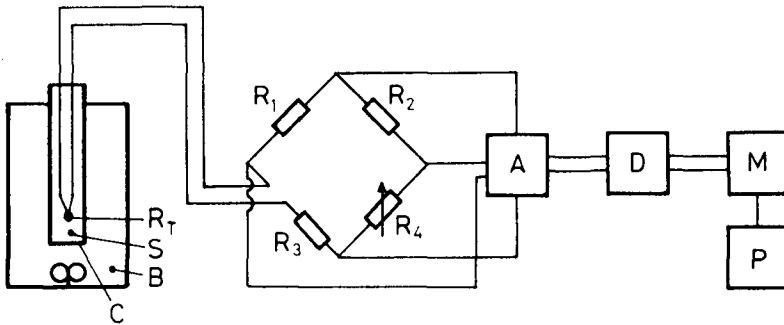

**Fig. 1** Schematic graph of the experimental apparatus. *C*-thermal conductivity cell; *S*-liquid sample;  $R_T$ -thermistor; *B*-thermostatic water bath;  $R_1$ ,  $R_2$ ,  $R_3$ -standard resistance;  $R_4$ -adjust resistance; *A*-amplifier and d,c, mains; *D*-diskette and fixed disk system; *M*-computer; *P*-printer

The thermal conductivity cell is cylindrical in form, 40 mm in length and 15 mm inner diameter. A specially made small bead of glass thermistor is used as the heating element. It is immersed in the liquid to be investigated. The thermistor is connected to an electric circuit of an unbalance bridge.  $R_1$ ,  $R_2$  and  $R_3$  are standard resistances, 1000  $\Omega$  each.  $R_T$  is resistance of the thermistor.

A steady current is passed through the thermistor immersed in the stationary liquid. Because the conductivity is different for different liquid, the rate of temperature change of the thermistor immersed in different liquid is not the same. It has been found that the rate of temperature change  $dT/dt$  is inversely proportional to the thermal conductivity  $\lambda$  of the liquid [3].

$$R_T = R_0 e^{B/T} \quad (2)$$

$$V = E \left( \frac{R_1}{R_1 + R_3 + R_T} - \frac{R_2}{R_2 + R_4} \right) \quad (3)$$

where  $V$  is voltage of unbalance bridge,  $E$  is the stable d.c. main potential. Substituting Eq. (2) into Eq. (3) and differentiating it with respect to temperature  $T$ , we obtain:

$$dV/dT = \frac{EBR_1}{T^2} \left( \frac{R_T}{R_1 + R_3 + R_T} \right) \quad (4)$$

The  $dV/dT$  is a function of temperature  $T$  and thermistor resistance  $R_T$ .  $E$ ,  $R_1$  and  $B$  are constants. The Eq. (4) shows that, if  $R_T$  is about  $3 \text{ k}\Omega$  and  $T$  is  $298.15 \text{ K}$ , then the  $dV/dT$  is maximum value, and if the temperature rise due to heating in experiment is within  $1^\circ\text{C}$ , the  $dV/dT$  can be considered as a constant.

$$S_i = dV/dt = dV/dT \cdot dT/dt = kdT/dt \quad (5)$$

The  $S_i$  is a rate of voltage change of the bridge and it is determined in experiment. Since  $dV/dT$  is constant, the  $S_i$  will also be inversely proportional to thermal conductivity of the liquids [4, 5].

## Experiment and results

Liquid sample is added into the thermal conductivity cell. A stable current  $0.041 \text{ mA}$  is passed through the thermistor bridge;  $R_4$  is adjusted to keep bridge in balance. Then a heating current of  $1.000 \text{ mA}$  is passed through the thermistor. The time constant of small thermistor immersed in the liquids is less than  $0.5 \text{ s}$ . The  $S_i$  is measured  $0.5 \text{ s}$  after heating current circuit is closed, and the measuring time is  $1 \text{ s}$ .

The apparatus system is comprised of hardware wherein experimental control, data acquisition and analysis are accomplished by a computer under soft-

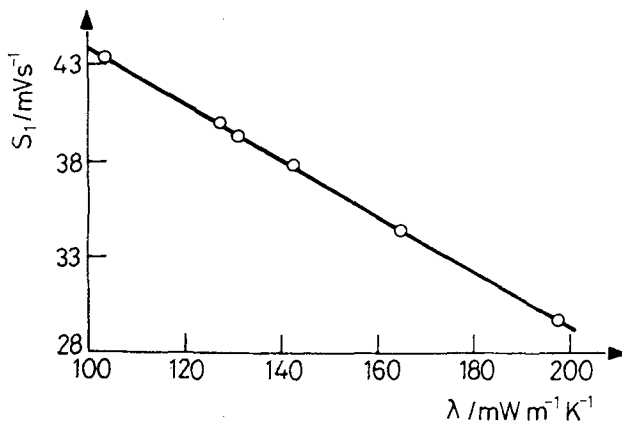

Fig. 2 The plot of  $\lambda$  vs.  $S_i$  for 6 reference liquids

ware control. In order to measure  $\lambda$  of organic liquids, six analytically pure liquids, methanol, ethanol, benzene, toluene, *n*-heptane and carbon tetrachloride, were taken as reference substances. The apparatus has been calibrated at 25°C by using these 6 liquids. Figures 2 shows a typical plot of  $\lambda$  vs.  $S_i$ .

The corresponding data have been calculated by means of least square. We obtained a calibration equation of the apparatus:

$$\lambda(\text{mW/mK}) = 391.80 - 6.589S_i \quad (6)$$

Table 1 shows the comparison between predicted values by Eq. (6) and the corresponding literature values.

**Table 1** The comparison of experiment  $\lambda_{\text{exp}}$ , and literature  $\lambda_{\text{lit}}$

Sample	$S_i/\text{mV}\cdot\text{S}^{-1}$	$\lambda_{\text{lit}}/\text{mW}\cdot\text{mK}^{-1}$	$\lambda_{\text{exp}}/\text{mW}\cdot\text{mK}^{-1}$	dev. / %
methanol	29.504	197.2 <sup>(6)</sup>	197.4	0.1
ethanol	34.528	164.2 <sup>(6)</sup>	164.3	0.1
benzene	37.928	142.1 <sup>(7)</sup>	141.9	0.1
toluene	39.445	131.6 <sup>(8)</sup>	131.9	0.2
<i>n</i> -heptane	40.280	127.5 <sup>(9)</sup>	126.4	0.8
carbon tetrachloride	43.800	102.5 <sup>(10)</sup>	103.2	0.7

The accuracy is better than 1%.

The  $S_i$  is mean value of six measurements, for toluene, and the  $S_i$ 's six in Table 2.

**Table 2** Six  $S_i$  and mean of toluene

No.	1	2	3	4	5	6	Mean
$S_i/\text{mV}\cdot\text{S}^{-1}$	39.504	39.452	39.429	39.427	39.453	39.453	39.453

In order to measure  $\lambda$  of aqueous solutions of the electrolytes, six liquids, aqueous solution of 30% KOH, 25% H<sub>2</sub>SO<sub>4</sub>, 10% NaCl, 20% NaCl, 20% ethanol and water were taken as reference samples. As mentioned above, the apparatus has been calibrated. We obtained the calibration Eq. (7) and Table 3.

$$\lambda(\text{mW/mK}) = 1381.3 - 49.9S_i \quad (7)$$

## Discussion

Being a comparative method, the accuracy depends on the uncertainty of the thermal conductivity values of reference liquids. In order to maintain accuracy, six reference liquids were used to calibrate the apparatus and the corresponding data were calculated by means of least square.

**Table 3** The comparison of  $\lambda_{\text{exp}}$  and  $\lambda_{\text{lit}}$ 

Sample	$S_i/mV\cdot S^{-1}$	$\lambda_{\text{exp}}/mW\cdot mK^{-1}$	$\lambda_{\text{lit}}/mW\cdot mK^{-1}$	dev./%
water	15.448	611.1	610 <sup>(11)</sup>	0.1
30% KOH	15.846	591.2	590 <sup>(11)</sup>	0.2
25% H <sub>2</sub> SO <sub>4</sub>	16.840	541.7	539 <sup>(12)</sup>	0.5
20% CH <sub>3</sub> CH <sub>2</sub> OH	18.178	475.0	476 <sup>(11)</sup>	0.2
10% NaCl	15.856	590.7	591 <sup>(13)</sup>	1.0
20% NaCl	15.946	586.3	584 <sup>(13)</sup>	0.4

The accuracy is better than 1%.

The measuring time is 1 s and the temperature rise is within 1°C, so that the effects of convection and radiation may be neglected.

The stability of this thermistor is not very good. The change in resistance is about 0.1% for one year. When obvious change in resistance is discovered, the apparatus will be calibrated once again.

From measured values of  $S_i$  of toluene (in Table 2), we find that the precision of measurement is better than 0.2%. Such an apparatus is also applicable for rapid compositional analysis.

\* \* \*

The authors wish to thank to the Xi'an Beiguang Dianzi Company for financial support.

## References

- George M. Mallan *et al.* *J. Chem. Eng. Data*, 17 (1972) 412.
- R. C. Reid, J. M. Prausnitz and T. K. Sherwood, 'The properties of Gases and Liquids' 3d ed. McGraw-Hill, New York 1977 p. 525.
- D. J. Eatough, *Thermochim. Acta*, 3 (1972) 333.
- C. Y. Wang, C. Sh. Guo and M. L. Yang, *J. Chem. Industry Eng., (China)* (3) (1984) 274.
- C. Y. Wang and M. L. Yang, *J. Chem. Industry Eng., (China)* (4) (1989) 494.
- H. Poltz and R. Jugel, *Int. J. Heat Mass Transfer*, 10 (8) (1967) 1075.
- H. Poltz, *Int. J. Heat Mass Transfer*, 8 (4) (1965) 609.
- J. F. T. Plattman, Fluid thermal conductivity determination by the transient line source method. Ph. D. Thesis. Imperial College of Science and Technology, Department of Chemical Engineering 1968.
- N. B. Vargaftik, *Table on the Thermophysical Properties of Liquids and Gases*, Hemisphere, 1975, p. 269.
- E. Schmidt and W. Leidenfrost, *Chem. Ing. Tech.*, 26 (11) (1954) 35.
- N. B. Vargaftik, *Table on the Thermophysical properties of liquids and Gases*, Hemisphere, 1975 p. 687.
- N. B. Vargaftik, *Table on the Thermophysical properties of liquids and Gases*, Hemisphere, 1975 p. 686.
- N. B. Vargaftik, *Table on the Thermophysical properties of liquids and Gases*, Hemisphere, 1975 p. 685.

**Zusammenfassung** — Es wurde ein neues, vollständig rechnerkontrolliertes Kalorimeter zur Messung der Wärmeleitfähigkeit von Flüssigkeiten konstruiert. Die Meßzeit beträgt 1 s und die Temperaturerhöhung infolge des Erhitzens bleibt innerhalb 1°C. Als Bezugssubstanzen wurden sechs organische Flüssigkeiten und sechs wäßrige Lösungen von Elektrolyten verwendet. Das Gerät wurde bei 25°C kalibriert. Die Genauigkeit ist besser als 1%, der Meßfehler etwa 0.2%.